

Dry-Ink Coding Left Feed

CONTINUOUS BAND SEALERS

HL-M810 is suitable for sealing all types of thermoplastic materials and bags. This sealer can be used in a variety of fields such as the food, medical, and cosmetic industries. Can seal 20-30 6" poly bags in one minute. HL-M810 uses dry ink coding to print numbers or letters on the seal line.

FEATURES

- Durable stainless steel construction
- Easy to operate – minimal operator training
- Fast warm up time
- Solid state digital temperature controller to maintain seal bars at proper temperature for consistent seal quality
- Fully adjustable conveyor (conveyor height and depth in relation to seal bars can be adjusted)
- Motorized rubber conveyor for speed control
- Knurled pressure rolls with variable pressure adjustment
- Sealing method – constant/direct heat accompanied with a pair each of cooling and heating blocks
- Unit feeds left to right (For right to left feed, see FRM-1120C and FRM-1010)
- Spare parts includes: PC Board, PTFE belt, wheel belt, fuse, motor brush, heating element, silica gel ring, silicone pin, and type set

OPTIONS

- Stainless steel stand for horizontal models
- Dry ink coding – font size – 10.5PT (standard is 18.5PT)

SPECIFICATIONS	
POWER	110V / 60Hz
MOTOR POWER	50W
SEALING SPEED	0-472 INCHES/MINUTE
SEAL WIDTH	8MM
TEMPERATURE RANGE	0-300°C
SEALING POWER	300 X 2
CONVEYOR SIZE	37" x 6"
MAX CONVEYOR LOAD	6.6LBS
BAG SIZE (FILLED)- VERTICAL	MINIMUM - 7 7/8" MAXIMUM – 12"
CHARACTER SIZE	TWO TYPES AVAILABLE R-TYPE: PT 18PT – 2 LINES OPTION: PT 10.5 – 3 LINES
PRINTING HEATING POWER (W)	40 x 2
PRINTING OPTIONS	20 CHARACTERS/LINE
DIMENSIONS	37" x 16" x 17"
WEIGHT	HORIZONTAL -85lbs VERTICAL – 95lbs



HL-M810I



HL-M810II

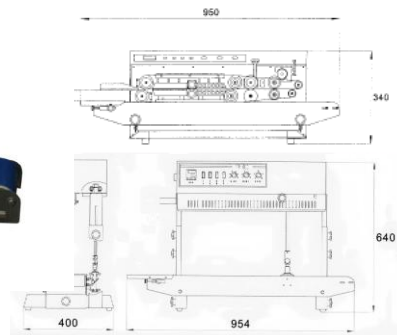

Measurements in mm

Dry-Ink Coding Left Feed

CONTINUOUS BAND SEALERS

HL-M810II - Vertical



Guide
Bag entry guide



Sealing Height Knobs
Adjust sealing height on both sides of supports



Pressure Knob Adjustment



Circuit Breaker
Flip circuit breaker to "on" position

Guide
Bag entry guide

HL-M810I - Horizontal

Ink Wheel Adjusting Device
Lighten or darken print on seal line



Printing Wheel
Place types in wheel for printing



Ink Roller
Various ink roller colors available



Conveyor Height Adjustment
Adjusts height of conveyor table (30-40mm) - Horizontal Only

Control Panel

Power Switch

Conveyor Speed Adjustment

Ink Temperature Adjustment

Heat Switch
Turns on temperature controller to activate sealing



Emergency Stop

Coding Seat
Adjusts printing position

Printing Switch
Activates printing function (dry ink coding)

Fan

Digital Temp Controller